

AseptiMix™ MI 3D Single Use Mixer Bags

Biopharmaceutical process involves a very wide range of process fluids such as media, growth regulators, harvests, post centrifuge supernatants, buffers, process intermediates and formulations.

A critical requirement is mixing of many of these fluids during and between process step(s) as well as between different process areas. Process owners using conventional mixing systems involving glass bottles, large carboys or stainless steel vessels face multiple challenges in terms of extraneous contamination due to multiple open system handling, cleaning validation and documentation.

Single Use Systems

Single use disposable pre-sterilized mixer systems help overcome all the above functional challenges and help achieve greater regulatory compliance. These systems however, need to address user concerns with respect to integrity and strength, sterility, endotoxins, biosafety, extractables, particle/fiber release that may impact the identity, strength, quality and purity of the process fluids.

mdi AseptiMix™ MI 3D mixer bags provide validated and reliable mixing solutions for biopharmaceutical process requirements such as mixing of media, process intermediates, sterile buffers with wide ranging pH, and formulations. These are well characterized for various physical, chemical and microbiological properties to alleviate all the above mentioned concerns. These mixer bags replace the need of mixing in open tank liner systems.

mdi AseptiMix™ MI single use mixer bags are designed for uniform and fast mixing of cell culture media, process fluids, buffers, reagents and formulations. The impeller is located inside the *AseptiMix™ MI* mixer bags which is rotated with the help of magnetic drive. The *AseptiMix™ MI* mixer bag is also available with 4" and 8" sanitary flange powder port for powder-to-liquid mixing.

The **mdi AseptiMix™ MI** mixer bags are available for volumes upto 1000 liters.

AseptiFlex-D

Datasheet

Film for AseptiMix™ MI Mixer Bags

The **mdi AseptiFlex-D** Film type FBG-1 is a highly inert, multilayered polyethylene film specially designed for bioprocess applications.

The film is physically tough and inert to chemicals and solvents used in the biopharmaceutical industry and the various layers of the film provide an excellent barrier to Oxygen, CO₂ and moisture.

The contact layer is 130 µm ultra low density Polyethylene layer without any additives.

The AseptiFlex-D film is produced in classified areas through validated processes to ensure consistently high quality meeting various regulatory as well as functional requirements.

Deeply characterized and validated

AseptiFlex-D has been extensively characterized after gamma irradiation at 50 kGy to deliver high performance:

High strength and flexibility: for safety and integrity during handling, storage and transport

Test		Reference Standard	Average Values
Tear strength	TD	ASTMD1938	25.556 N
	MD		17.873 N
Puncture Resistance		EN14477	10.9578 N
Tensile Strength (MD)		ASTMD-882	27.0298 N/mm ²
Flex Durability Test (Gelbo)		ASTM F-392	Passes

Protection of stored liquids from oxidation, change in pH and change in concentration of critical components: with high barrier properties for Oxygen (O₂), Carbon dioxide (CO₂) and water vapour (WV)

Test	Reference Standard	Average Values
O ₂ Transmission Rate	ASTMD3985-05	0.168 cc/m ² /day
CO ₂ Transmission Rate	ASTMF2476	<1.0 cc/m ² /day
WV Transmission Rate	ASTMF1249-13	0.879 g/m ² /day

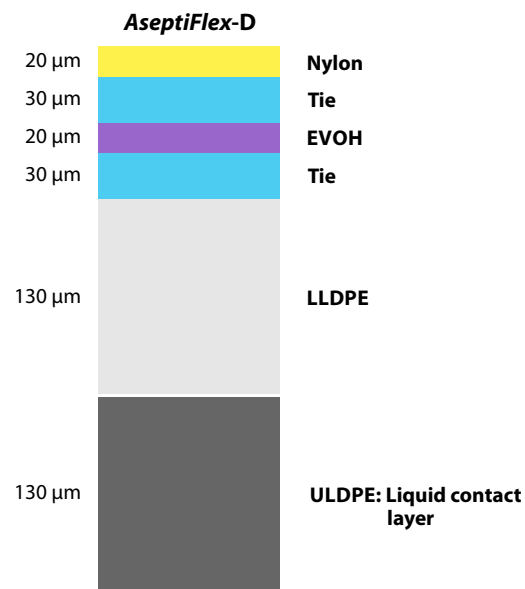

Biocompatibility for media storage and cell growth:

AseptiFlex film is made of plastics of Non Animal Origin and is validated for Biological Reactivity tests as per USP

Test	Reference Standard	Result
Intracutaneous Toxicity	Biological Reactivity Tests, <i>In Vivo</i> , as per USP <88>	Passes
Acute Systemic Toxicity		Passes
Muscle Implantation		Passes
Cytotoxicity	Biological Reactivity Tests, <i>In Vitro</i> , USP <87>	Passes

No impact on purity of process fluids: Very low extractable profile

Test	Reference Standard	Result
Non Volatile Residue	as per USP <661>	Passes
Heavy Metals	as per USP <661>	Passes
Buffering Capacity	as per USP <661>	Passes
Effect on WFI	as per USP <1231>	Passes

AseptiMix™ MI

Datasheet

Unique Features and Applications

AseptiMix™ MI is made from AseptiFlex-D film offering multiple advantages such as:

- Uniform and fast mixing
- Customized to user requirements
- Very low extractable profile for low 'Product' risk

Unique Features

- Custom designed to suit user specific process applications
- Multiple Impeller options for uniform and easy mixing
- Available with 4" and 8" sanitary flange powder ports for powder-to-liquid mixing
- Easy inlet and outlet quick connections
- 100% integrity tested with pressure leak test

Applications

mdi AseptiMix™ MI mixer bags are used for critical biopharmaceutical process steps involving:

- Mixing and transfer of
 - Cell culture media
 - Buffers
 - Formulations
 - Process intermediates

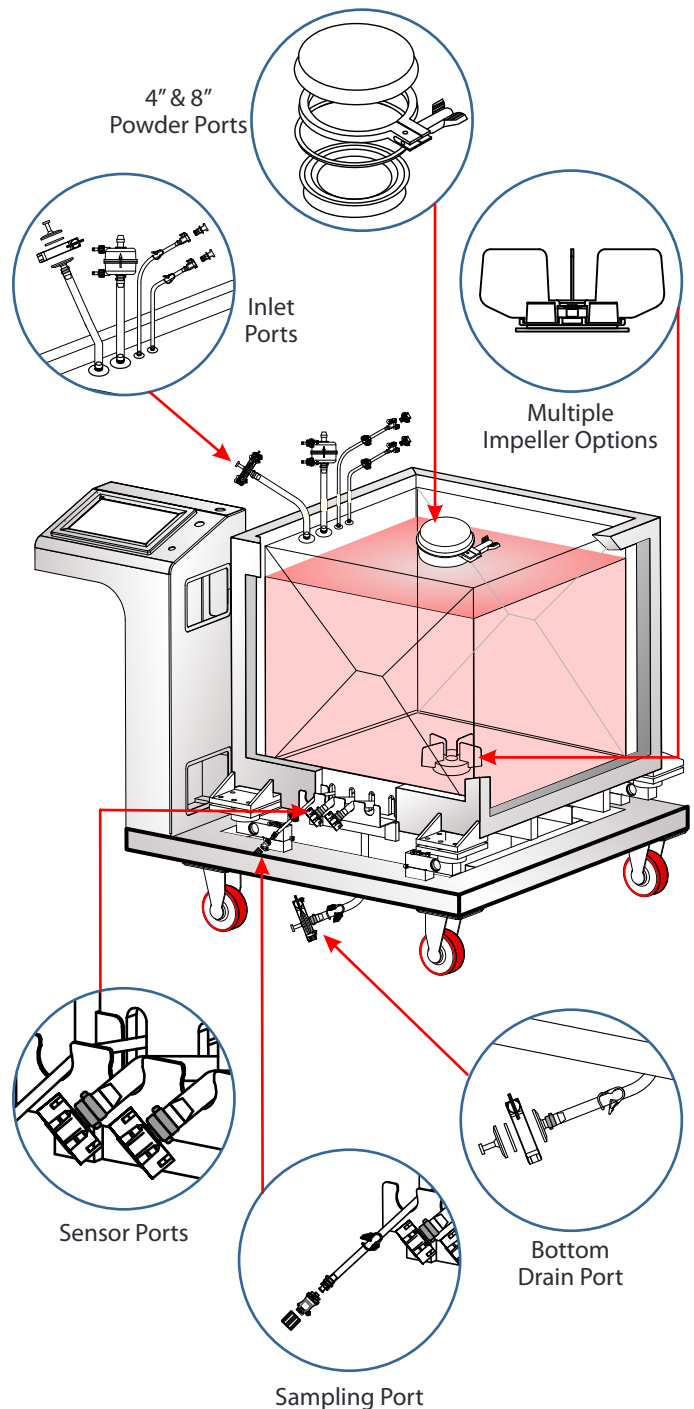

Working of Mixer Bags

Working of AseptiMix™ MI Mixer Bags

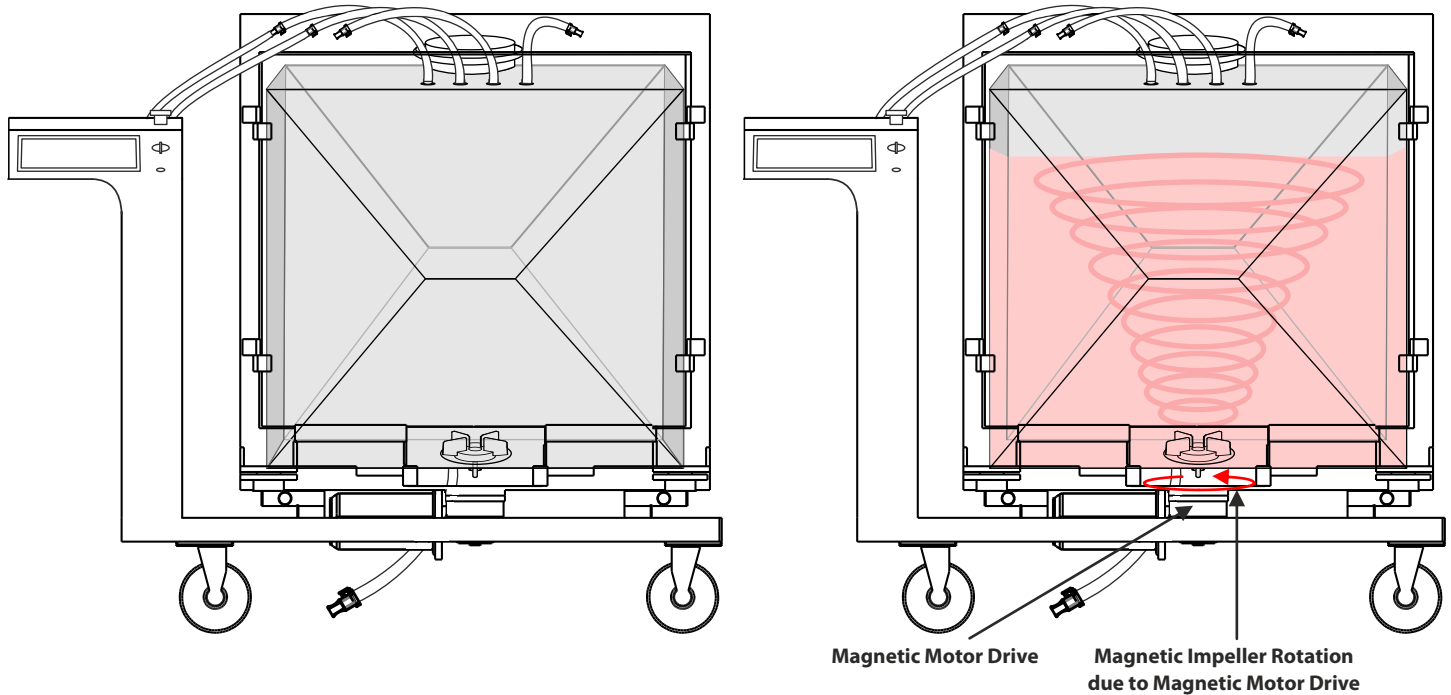

Installed AseptiMix™ MI Mixer Bags in BioMixer™ MI Mixer Systems

The mixing process in **mdi** AseptiMix™ MI single use mixer bags is carried with magnetic impeller which is coupled with pre-fitted magnetic motor drive unit on **mdi** BioMixer™ MI mixer systems through magnetic forces. There are no dynamic seals or shaft penetration inside the mixer bag.

By switching ON the motor through BioMixer™ MI control panel, magnetic motor drive induces rotation of the impeller inside the AseptiMix™ MI mixer bag resulting in the mixing action inside the bag.

Quality Assurance

mdi quality management system emphasizes on quality by design rather than by end product testing only. Robust processes are developed for product manufacturing and are continuously monitored to ensure that the products meet their predetermined specifications and lot to lot reproducibility is ensured.

mdi AseptiMix™ MI mixer bags are produced by trained personnel in validated ISO class 7 facilities under ISO 9001 quality management systems using validated production processes.

Each lot has well compiled batch manufacturing records that ensure complete traceability of raw materials, machines, in process controls, personnel and quality control test data.

These are tested and validated as per international standards and guidelines such as CFR, ASTM, ISO and USP and supported by well designed, state of art physical, chemical and microbiology laboratories.

100% Integrity Tested

Each **mdi** AseptiMix™ MI is tested for integrity to comply with validated Acceptable Integrity Test Specifications.

Pressure, Temperature Endurance

AseptiMix™ MI mixer bags are validated to endure operating pressure and wide temperature conditions which may be encountered during use.

These bags are also validated for burst pressure with liquid to ensure user as well as product safety in case of inadvertent pressure build-up.

Bioburden Testing

Bioburden is tested as per ISO 117 37-1 and assured to be <1000 cfu/bag.

Biosafety

Passes Biological Reactivity test, *In-Vivo*, as per USP <88> for Class VI plastics

Passes the Biological Reactivity Tests, *In Vitro* for Cytotoxicity as described in USP <87>

Endotoxin Testing

Aqueous extracts exhibit < 0.25 EU/ml as established by Limulus Amebocyte Lysate (LAL) Test as per USP <85>

Extractables

Extractables/leachables from sterile containers, used at various stages of a biopharmaceutical manufacturing process, will add on and may impact the impurity profile of the desired product.

AseptiMix™ MI mixer bags are validated to exhibit very low extractables under harsh extraction conditions.

Package Integrity

AseptiMix™ MI mixer bags are double packed in polybags to ensure package integrity during transit as well as to prevent contamination while transferring to clean room assembly or process areas.

Certificate of Quality

Each lot is accompanied with a Certificate of Quality and the lot number is mentioned on the packaging of each AseptiMix™ MI mixer bags to ensure traceability at the user's end.

AseptiMix™ MI

Specifications

Datasheet

Materials of Construction

Bag Film	AseptiFlex-D film type FBG-1
Impeller	Polypropylene
Ports	LDPE
Tubing	Thermoplastic Elastomer
	Platinum cured silicone

Sterilization

Gamma Sterilizable upto 50kGy

Sterility

The gamma sterilization process has been validated as per ISO 11137 to ensure a sterility assurance level(SAL) of 10^{-6}

Bacterial Endotoxin

Aqueous extracts exhibit < 0.25 EU/ml as established by Limulus Amebocyte Lysate (LAL) Test as per USP <85>

Biosafety

Passes the Biological Reactivity Tests, *In Vivo* for Class VI plastics as described in USP <88>.

Fiber Release

Passes test as per USP and comply with USFDA 21 CFR Part 210.3(b)(6) for fiber release

Particle Release

Complies with USP <788> test for particulate matter in injections

Extractables with WFI

Does not affect the quality of Water for Injection (passes tests as per USP <661>)

Available Sizes

50L, 100L, 200L, 650L and 1000L

Dimensions

Bag Size	A	B	C
50 Litre	400 mm	400 mm	360 mm
100 Litre	490 mm	490 mm	465 mm
200 Litre	600 mm	600 mm	575 mm
650 Litre	890 mm	890 mm	865 mm
1000 Litre	1040 mm	1040 mm	1000 mm

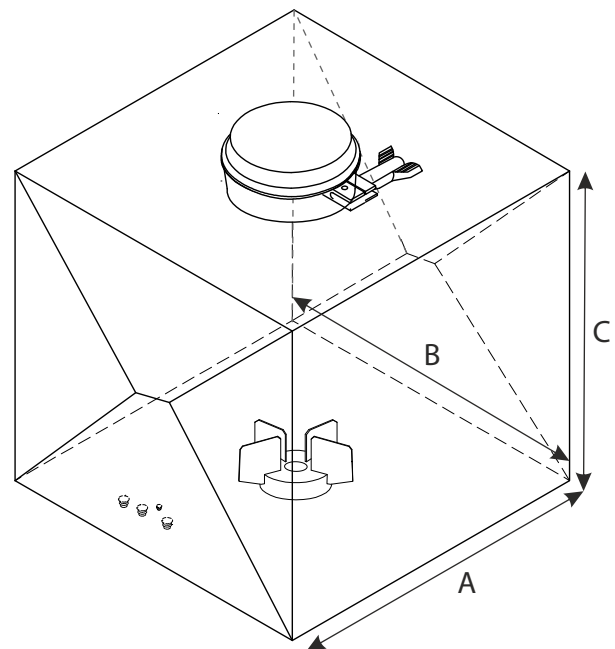

AseptiMix™ MI

Datasheet

Customized Single Use Mixer Bags

mdi AseptiMix™ MI mixer systems are suitable for liquid-to-liquid as well as powder-to-liquid mixing. An optional powder port with 8" sanitary flange is available for addition of powders.

mdi works closely with the process owners in biopharmaceutical manufacturing to understand their application requirements in order to establish the technical feasibility of a single use mixing system in terms of pressure, temperature, complexity of the system as well as compatibility, and to design customized systems by integrating AseptiMix™ MI with a wide range of pre-qualified components such as membrane capsule filters, connectors, tubing and fittings.

All the system components are deeply characterized and validated for microbial retention, bio-burden, bacterial endotoxins, biosafety and extractables etc to minimize 'product risk' and maximize regulatory compliance.

These customized systems are realized from user approved drawings with detailed definitions of materials of constructions, pore size and dimensions.

Components

Sterilizing grade membrane capsule filters

mdi capsule filters with PES and hydrophilic PVDF membranes are available in different pore sizes, sizes and end connections for sterile filtration of cell culture media, buffers, drug substance and drug formulations. To know more, visit the link:

<http://www.mdimembrane.com/microfiltration/product-by-type/capsule-filter>

Tubing

mdi offers multiple tubing options of thermoplastic elastomers (TPE) as well as platinum cured silicone. These are available in a wide range of internal and outer diameters to meet the process requirements with respect to fitment into peristaltic pump and to different size hose connections.

TPE tubing offers chemical compatibility with a wide range of organic solvents and buffers. These are heat weldable to allow leak free sterile connections for sampling and storage applications.

Platinum cured silicone tubing offers enhanced flexibility for easy integration into single use systems and for use in peristaltic pumps.

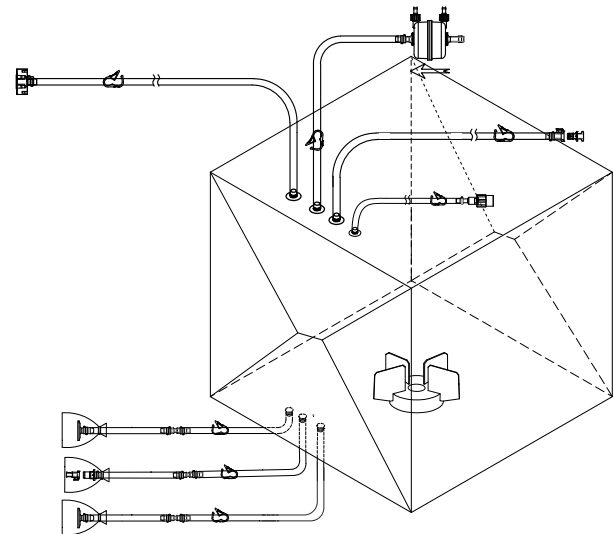

**AseptiMix™ MI Mixer Systems
for liquid to liquid mixing**

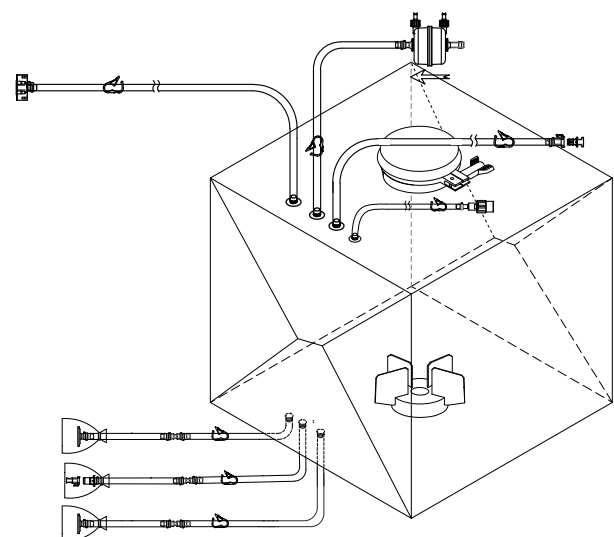

**AseptiMix™ MI Mixer Systems
for powder to liquid mixing**

Fittings

A wide range of **mdi** gamma stable fittings such as cross connections, T connections, Y connections and reducers are available to support various plumbing requirements within these customized single use systems.

Customized Single Use Mixer Bags

Product Realization

These AseptiMix™ MI mixing systems can be customized to suit user requirements regarding tubing sizes, type of inlet ports, sampling ports, and position and type of drain ports. A technical feasibility of the required design is established based on available components and an initial drawing is proposed. Products prototyping and final approval leads to customized mixer bag realization.

Product Realization Flow Chart

